

### Cosmetic mirror 950.01.225

- round, unilluminated
- double-sided mirror, both sides mirrored, rotatable
- set in a chrome-plated metal frame
- one side concave, one side flat
- 3-fold magnification
- mirror diameter 200 mm, mirror surface diameter 190 mm
- on double-hinged arm, mounting allows movement, length 365 mm
- for wall mounting, concealed 3-point fixing
- wall connection diameter 58 mm, 10 mm deep
- including non-corrosive HEWI fixing material
- high-quality chrome-plated

### Dimensions in mm

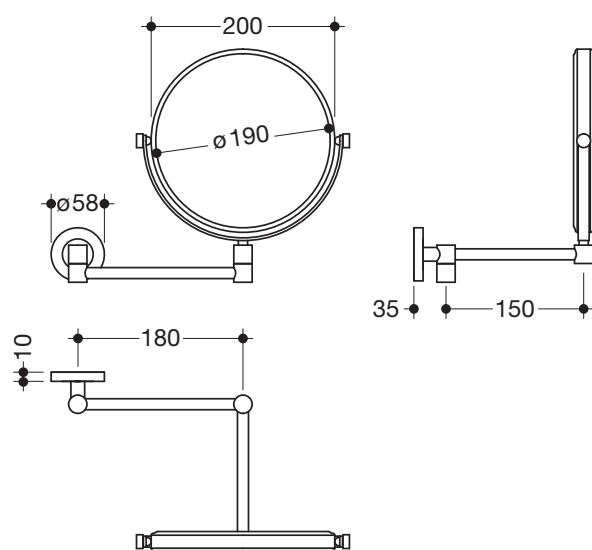

### Surface

chrome

Technical information subject to alteration, 30th September 2021

HEWI Heinrich Wilke GmbH  
Postfach 1260  
D-34442 Bad Arolsen

Telefon: +49 5691 82-366  
Telefax: +49 5691 82-99366  
international@hewi.com  
www.hewi.com

HEWI (UK) Limited  
Holm Oak Barn, Beluncle Halt  
Stoke Road  
Hoo Kent ME3 9NT

Phone +44 1634 258 200  
Fax +44 1634 250 099  
info@hewi.co.uk  
www.hewi.com